

# Specifications R180LC-9A

## ENGINE

MODEL	PERKINS 1204E	
Type	Water cooled, 4 cycle Diesel, 4-Cylinders in line, direct injection, turbocharged, charged air cooled and low emission	
Rated flywheel horse power		
SAE	J1995 (gross)	137 HP (102.2 kW) / 2,050 rpm
	J1349 (net)	128 HP (96 kW) / 2,050 rpm
DIN	6271/1 (gross)	139 PS (102.2 kW) / 2,050 rpm
	6271/1 (net)	130 PS (96 kW) / 2,050 rpm
Max. torque	57.1 kgf.m (413 lbf.ft) / 1,500 rpm	
Bore x stroke	105 x 127 mm (4.13" x 5.0")	
Piston displacement	4,400 cc (268.5 in <sup>3</sup> )	
Batteries	2 x 12 V x 100AH	
Starting motor	24 V- 4.5 kW	
Alternator	24 V- 80 Amp	

\* This engine meets the EPA (Tier 4 interim) / EU (Stage III-B) Emission regulation.

## HYDRAULIC SYSTEM

MAIN PUMP	
Type	Variable displacement axial piston pumps
Max. flow	2 x 160 l/min (44.4 US gpm / 37.0 UK gpm)
Sub-pump for pilot circuit	Gear pump

Cross-sensing and fuel saving pump system

HYDRAULIC MOTORS	
Travel	Two-speed axial piston motor with brake valve and parking brake
Swing	Axial piston motor with automatic brake

RELIEF VALVE SETTING	
Implement circuits	350 kgf/cm <sup>2</sup> (4,980 psi)
Travel	350 kgf/cm <sup>2</sup> (4,980 psi)
Power boost (boom, arm, bucket)	380 kgf/cm <sup>2</sup> (5,410 psi)
Swing circuit	285 kgf/cm <sup>2</sup> (4,050 psi)
Pilot circuit	40 kgf/cm <sup>2</sup> (570 psi)
Service valve	Installed

HYDRAULIC CYLINDERS	
No. of cylinder-bore x stroke	Boom: 2-115 x 1,090 mm (4.5" x 42.9")
	Arm: 1-120 x 1,355 mm (4.7" x 53.3")
	Bucket: 1-110 x 995 mm (4.3" x 39.2")
	Blade: 2-110 x 320 mm (4.3" x 12.6")
	2PC- 1st: 2-115 x 960 mm (4.5" x 37.8")
	boom 2nd: 1-160 x 650 mm (6.3" x 25.6")

## DRIVES & BRAKES

Drive method	Fully hydrostatic type
Drive motor	Axial piston motor, in-shoe design
Reduction system	Planetary reduction gear
Max. drawbar pull	17,000 kgf (37,500 lbf)
Max. travel speed (high) / (low)	5 km/h (3.1 mph) / 3.2 km/h (2.0 mph)
Gradeability	30° (58 %)
Parking brake	Multi wet disc

## CONTROL

Pilot pressure operated joysticks and pedals with detachable lever provide almost effortless and fatigueless operation.

Pilot control	Two joysticks with one safety lever (LH): Swing and arm (RH): Boom and bucket (ISO)
Traveling and steering	Two levers with pedals
Engine throttle	Electric, Dial type

## SWING SYSTEM

Swing motor	Two fixed displacement axial piston motor
Swing reduction	Planetary gear reduction
Swing bearing lubrication	Grease-bathed
Swing brake	Multi wet disc
Swing speed	11.2 rpm

## COOLANT & LUBRICANT CAPACITY

	liter	US gal	UK gal
Refilling			
Fuel tank	270	71.3	59.4
Engine coolant	15.5	4.1	3.4
Engine oil	10.5	2.8	2.3
Swing device-gear oil	5.0	1.3	1.1
Final drive (each)-gear oil	5.8	1.5	1.3
Hydraulic system (including tank)	270	71.3	59.4
Hydraulic tank	160	42.3	35.2

## UNDERCARRIAGE

The X-leg type center frame is integrally welded with reinforced box-section track frames. The undercarriage includes lubricated rollers, idlers, track adjusters with shock absorbing springs and sprockets, and a track chain with double or triple grouser shoes.

Center frame	X - leg type
Track frame	Pentagonal box type
No. of shoes on each side	51
No. of carrier rollers on each side	2
No. of track rollers on each side	7
No. of rail guards on each side	2

## OPERATING WEIGHT (APPROXIMATE)

Operating weight, including 5,100 mm (16' 9") boom, 2,600 mm (8' 6") arm, SAE heaped 0.76 m<sup>3</sup> (0.99 yd<sup>3</sup>) bucket, lubricant, coolant, full fuel tank, full hydraulic tank and all standard equipments.

MAJOR COMPONENT WEIGHT	
Upperstructure	4,980 kg (10,980 lb)
5.1 m (16' 9") mono boom (with arm cylinder)	1,250 kg (2,760 lb)
Hydraulic adjustable boom (with arm cylinder)	1,780 kg (3,920 lb)

OPERATING WEIGHT			
Shoes		Operating weight	Ground pressure
Type	Width mm (in)	kg (lb)	kgf/cm <sup>2</sup> (psi)
Triple grouser	500 (20")	R180LC-9A	18,350 (40,450) 0.51 (7.25)
		R180LCD-9A	19,350 (42,660) 0.53 (7.54)
		R180NLC-9A	18,260 (40,260) 0.50 (7.11)
	600 (24")	R180LC-9A	18,600 (41,010) 0.43 (6.11)
		R180LCD-9A	19,600 (43,210) 0.45 (6.40)
		R180NLC-9A	18,510 (40,810) 0.43 (6.11)
	700 (28")	R180LC-9A	18,850 (41,560) 0.37 (5.26)
		R180LCD-9A	19,850 (43,760) 0.39 (5.55)
		R180LC-9A	19,100 (42,110) 0.33 (4.69)
	800 (32")	R180LC-9A	20,100 (44,310) 0.35 (4.98)

## BUCKETS R180LC-9A

All buckets are welded with high-strength steel.

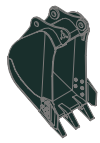

0.39 (0.51)

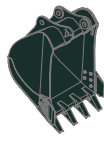

0.50 (0.65)

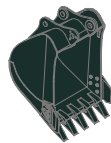

0.64 (0.84)

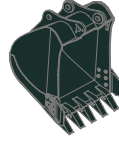

0.76 (0.99)

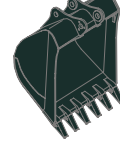

0.89 (1.16)

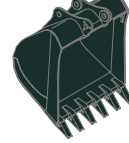

1.05 (1.37)

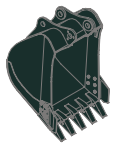

■ 0.69 (0.90)

SAE heaped m<sup>3</sup> (yd<sup>3</sup>)

Capacity m <sup>3</sup> (yd <sup>3</sup> )		Width mm (in)		Weight kg (lb)	Recommendation m (ft.in)				
SAE heaped	CECE heaped	Without side cutters	With side cutters		5.1 (16' 9") Mono Boom			5.1 (16' 9") Hydraulic Adjustable Boom	
					2.2 (7' 3") Arm	2.6 (8' 6") Arm	3.1 (10' 2") Arm	2.2 (7' 3") Arm	2.6 (8' 6") Arm
0.39 (0.51)	0.34 (0.44)	620 (24.4)	740 (29.1)	410 (900)	●	●	●	●	●
0.50 (0.65)	0.44 (0.58)	760 (29.9)	880 (34.6)	470 (1,040)	●	●	●	●	●
0.64 (0.84)	0.55 (0.72)	920 (36.2)	1,040 (40.9)	510 (1,120)	●	●	■	●	■
0.76 (0.99)	0.65 (0.85)	1,060 (41.7)	1,180 (46.5)	570 (1,260)	●	■	▲	■	▲
0.89 (1.16)	0.77 (1.01)	1,220 (48.0)	1,340 (52.8)	610 (1,340)	■	▲	—	▲	—
1.05 (1.37)	0.90 (1.18)	1,400 (55.1)	1,520 (59.8)	680 (1,500)	▲	—	—	▲	—
■ 0.69 (0.90)	0.62 (0.81)	990 (39.0)	-	700 (1,540)	●	■	▲	■	▲

■ Heavy-duty bucket

● : Applicable for materials with density of 2,000 kg/m<sup>3</sup> (3,370 lb/yd<sup>3</sup>) or less

■ : Applicable for materials with density of 1,600 kg/m<sup>3</sup> (2,700 lb/yd<sup>3</sup>) or less

▲ : Applicable for materials with density of 1,100 kg/m<sup>3</sup> (1,850 lb/yd<sup>3</sup>) or less

## ATTACHMENT R180LC-9A

Booms and arms are welded, a low-stress, full-box section design.

5.1 m (16' 9") boom & 5.1 m (16' 9") hydraulic adjustable boom and 2.20 m (7' 3"); 2.60 m (8' 6") & 3.10 m (10' 2") arms are available.

## DIGGING FORCE R180LC-9A

Boom	Length	mm (ft-in)	5,100 (16' 9")			Remarks
	Weight	kg (lb)	1,250 (2,760)			
Arm	Length	mm (ft-in)	2,200 (7' 3")	2,600 (8' 6")	3,100 (10' 2")	Remarks
	Weight	kg (lb)	750 (1,560)	810 (1,790)	890 (1,960)	
Bucket digging force	SAE	kN	107.9 [117.2]	107.9 [117.2]	107.9 [117.2]	[ ]: Power Boost
		kgf	11,000 [11,940]	11,000 [11,940]	11,000 [11,940]	
		lbf	24,250 [26,330]	24,250 [26,330]	24,250 [26,330]	
	ISO	kN	123.6 [134.2]	123.6 [134.2]	123.6 [134.2]	
		kgf	12,600 [13,680]	12,600 [13,680]	12,600 [13,680]	
		lbf	27,780 [30,160]	27,780 [30,160]	27,780 [30,160]	
Arm crowd force	SAE	kN	87.2 [94.7]	77.3 [83.9]	69.0 [74.9]	[ ]: Power Boost
		kgf	8,890 [9,650]	7,880 [8,560]	7,030 [7,630]	
		lbf	19,600 [21,280]	17,370 [18,860]	15,500 [16,830]	
	ISO	kN	91.0 [98.8]	80.3 [87.2]	71.4 [77.5]	
		kgf	9,280 [10,080]	8,190 [8,890]	7,280 [7,900]	
		lbf	20,460 [22,210]	18,060 [19,600]	16,050 [17,430]	

Note: Boom weight includes arm cylinder, piping and pin

Arm weight includes bucket cylinder, linkage and pin

# Dimensions & Working Ranges

## DIMENSIONS R180LC-9A

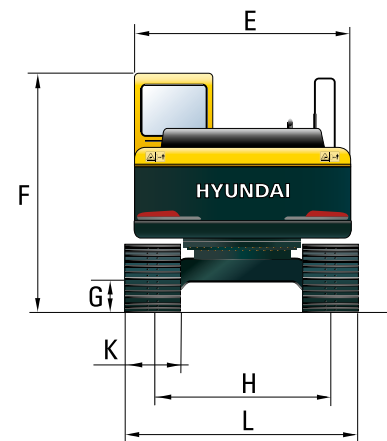
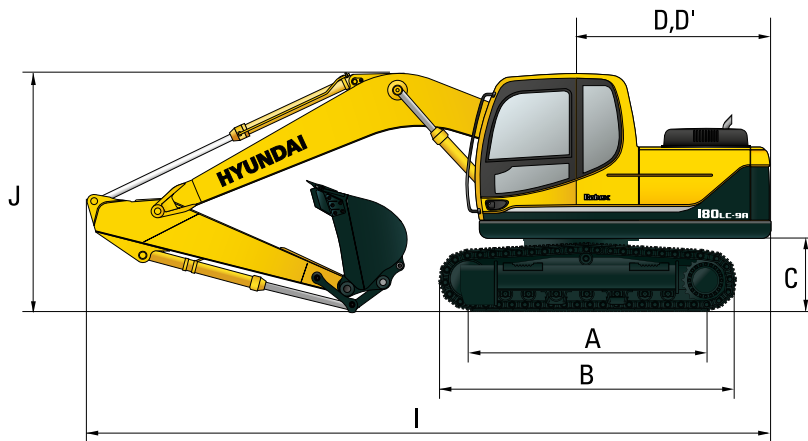

mm (ft · in)

mm (ft · in)

<b>A</b> Tumbler distance	3,360 (11' 0")	<b>Boom length</b> 5,100 (16' 9")			
<b>B</b> Overall length of crawler	4,150 (13' 7")	<b>Arm length</b>	2,200 (7' 3")	2,600 (8' 6")	3,100 (10' 2")
<b>C</b> Ground clearance of counterweight	1,055 (3' 6")	<b>I</b> Overall length	8,660 (28' 5")	8,650 (28' 5")	8,650 (28' 5")
<b>D</b> Tail swing radius	2,530 (8' 4")	<b>J</b> Overall height of boom	3,010 (9' 11")	2,990 (9' 10")	3,150 (10' 4")
<b>D'</b> Rear-end length	2,480 (8' 2")	<b>K</b> Track shoe width	500 (20")	600 (24")	700 (28")
<b>E</b> Overall width of upperstructure	2,475 (8' 1")	<b>L</b> Overall width	2,750 (9' 1")	2,850 (9' 5")	2,950 (9' 9")
<b>F</b> Overall height of cab	2,980 (9' 9")				
<b>G</b> Min. ground clearance	460 (1' 6")				
<b>H</b> Track gauge	2,250 (7' 5")				

## WORKING RANGES R180LC-9A

mm (ft · in)

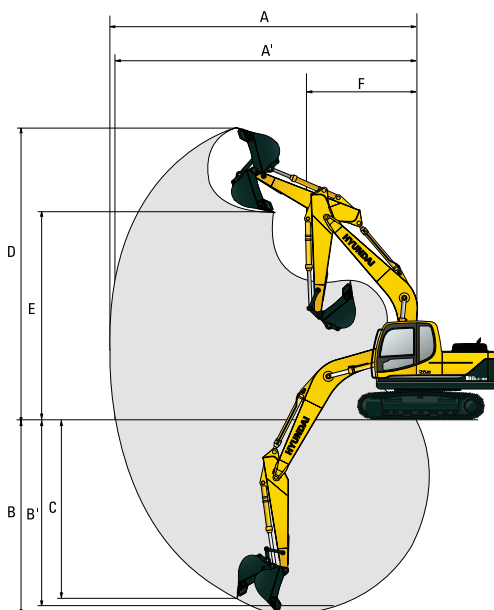

<b>Boom length</b>	5,100 (16' 9")		
<b>Arm length</b>	2,200 (7' 3")	2,600 (8' 6")	3,100 (10' 2")
<b>A</b> Max. digging reach	8,690 (28' 6")	9,020 (29' 7")	9,450 (31' 0")
<b>A'</b> Max. digging reach on ground	8,530 (27' 12")	8,860 (29' 1")	9,300 (30' 6")
<b>B</b> Max. digging depth	5,660 (18' 7")	6,060 (19' 11")	6,560 (21' 6")
<b>B'</b> Max. digging depth (8' level)	5,430 (17' 10")	5,850 (19' 2")	6,370 (20' 11")
<b>C</b> Max. vertical wall digging depth	5,120 (16' 10")	5,380 (17' 8")	5,710 (18' 9")
<b>D</b> Max. digging height	8,750 (28' 8")	8,840 (29' 0")	8,980 (29' 6")
<b>E</b> Max. dumping height	6,110 (20' 1")	6,220 (20' 5")	6,390 (21' 0")
<b>F</b> Min. front swing radius	3,180 (10' 5")	3,170 (10' 5")	3,170 (10' 5")

# Dimensions & Working Ranges

## DIMENSIONS R180NLC-9A

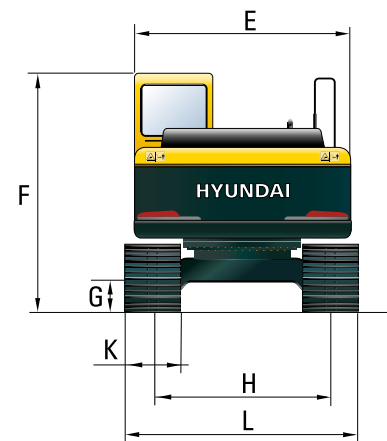
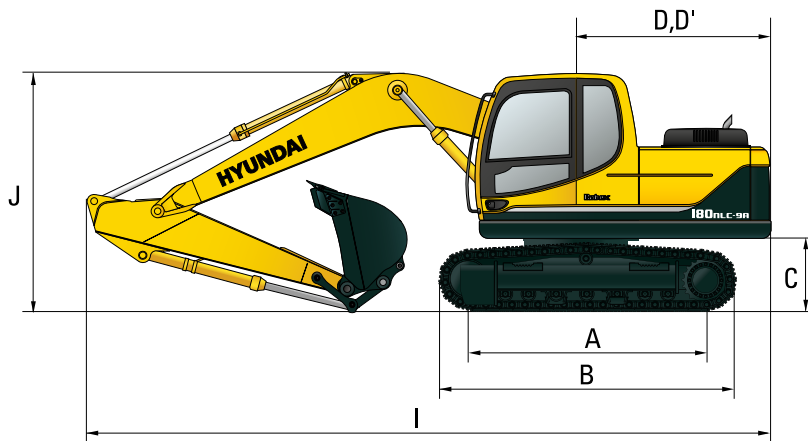

mm (ft · in)

mm (ft · in)

<b>A</b> Tumbler distance	3,360 (11' 0")	<b>Boom length</b>			5,100 (16' 9")		
<b>B</b> Overall length of crawler	4,150 (13' 7")	<b>Arm length</b>			2,200 (7' 3")	2,600 (8' 6")	3,100 (10' 2")
<b>C</b> Ground clearance of counterweight	1,055 (3' 6")	<b>I</b> Overall length			8,660 (28' 5")	8,650 (28' 5")	8,650 (28' 5")
<b>D</b> Tail swing radius	2,530 (8' 4")	<b>J</b> Overall height of boom			3,010 (9' 11")	2,990 (9' 10")	3,150 (10' 4")
<b>D'</b> Rear-end length	2,480 (8' 2")	<b>K</b> Track shoe width			500 (20")	600 (24")	
<b>E</b> Overall width of upperstructure	2,475 (8' 1")	<b>L</b> Overall width			2,500 (8' 2")	2,600 (8' 6")	
<b>F</b> Overall height of cab	2,980 (9' 9")						
<b>G</b> Min. ground clearance	460 (1' 6")						
<b>H</b> Track gauge	2,000 (6' 7")						

## WORKING RANGES R180NLC-9A

mm (ft · in)

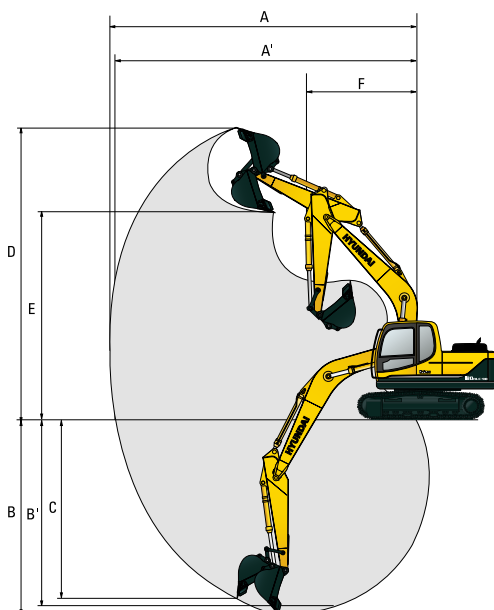

<b>Boom length</b>	5,100 (16' 9")		
<b>Arm length</b>	2,200 (7' 3")	2,600 (8' 6")	3,100 (10' 2")
<b>A</b> Max. digging reach	8,690 (28' 6")	9,020 (29' 7")	9,450 (31' 0")
<b>A'</b> Max. digging reach on ground	8,530 (27' 12")	8,860 (29' 1")	9,300 (30' 6")
<b>B</b> Max. digging depth	5,660 (18' 7")	6,060 (19' 11")	6,560 (21' 6")
<b>B'</b> Max. digging depth (8' level)	5,430 (17' 10")	5,850 (19' 2")	6,370 (20' 11")
<b>C</b> Max. vertical wall digging depth	5,120 (16' 10")	5,380 (17' 8")	5,710 (18' 9")
<b>D</b> Max. digging height	8,750 (28' 8")	8,840 (29' 0")	8,980 (29' 6")
<b>E</b> Max. dumping height	6,110 (20' 1")	6,220 (20' 5")	6,390 (21' 0")
<b>F</b> Min. front swing radius	3,180 (10' 5")	3,170 (10' 5")	3,170 (10' 5")

# Dimensions & Working Ranges

## DIMENSIONS R180LC-9A 2-PIECE BOOM

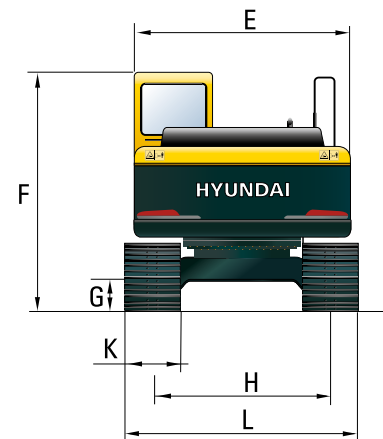
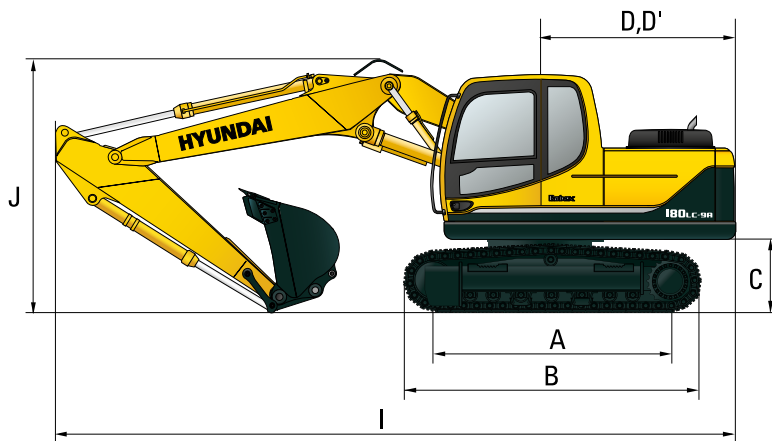

mm (ft · in)

mm (ft · in)

<b>A</b> Tumbler distance	3,360 (11' 0")	Boom length	5,100 (16' 9")	
<b>B</b> Overall length of crawler	4,150 (13' 7")	Arm length	2,200 (7' 3")	2,600 (8' 6")
<b>C</b> Ground clearance of counterweight	1,055 (3' 6")	<b>I</b> Overall length	8,610 (28' 3")	
<b>D</b> Tail swing radius	2,530 (8' 4")	<b>J</b> Overall height of boom	3,040 (9' 12")	
<b>D'</b> Rear-end length	2,480 (8' 2")	<b>K</b> Track shoe width	500 (20")	600 (24")
<b>E</b> Overall width of upperstructure	2,475 (8' 1")	<b>L</b> Overall width	2,750 (9' 1")	2,850 (9' 5")
<b>F</b> Overall height of cab	2,980 (9' 9")			700 (28")
<b>G</b> Min. ground clearance	460 (1' 6")			2,950 (9' 9")
<b>H</b> Track gauge	2,250 (7' 5")			

## WORKING RANGES R180LC-9A 2-PIECE BOOM

mm (ft · in)

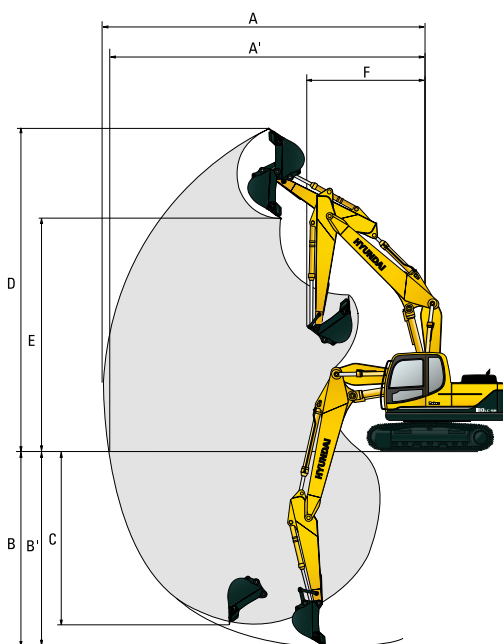











Boom length	5,100 (16' 9")	
Arm length	2,200 (7' 3")	2,600 (8' 6")
<b>A</b> Max. digging reach	8,760 (28' 9")	9,110 (29' 11")
<b>A'</b> Max. digging reach on ground	8,590 (28' 2")	8,950 (29' 4")
<b>B</b> Max. digging depth	5,430 (17' 10")	5,830 (19' 2")
<b>B'</b> Max. digging depth (8' level)	5,330 (17' 6")	5,730 (18' 10")
<b>C</b> Max. vertical wall digging depth	4,630 (15' 2")	4,980 (16' 4")
<b>D</b> Max. digging height	9,420 (30' 11")	9,610 (31' 6")
<b>E</b> Max. dumping height	6,710 (22' 0")	6,910 (22' 8")
<b>F</b> Min. front swing radius	3,100 (10' 2")	2,970 (9' 9")

# Lifting Capacities













## R180LC-9A

 Rating over-front  Rating over-side or 360 degrees













Boom : 5.10 m (16'9") / Arm : 2.20 m (7'3") / Bucket : 0.76 m<sup>3</sup> (0.92 yd<sup>3</sup>) SAE heaped / Shoe : 600 mm (24") triple grouser

Load point height m (ft)		Load radius								At max. reach		
		1.5 m (5ft)		3.0 m (10ft)		4.5 m (15ft)		6.0 m (20ft)		Capacity		Reach m (ft)
												
7.5 m (25ft)	kg									*3750	*3750	5.60
	lb									*8270	*8270	(18.4)
6.0 m (20ft)	kg									*3660	2920	6.98
	lb									*8070	6440	(22.9)
4.5 m (15ft)	kg					*4570	*4570	*4110	3690	*3690	2370	7.76
	lb					*10080	*10080	*9060	8140	*8140	5220	(25.5)
3.0 m (10ft)	kg			*9100	*9100	*5790	5620	*4600	3550	3360	2130	8.15
	lb			*20060	*20060	*12760	12390	*10140	7830	7410	4700	(26.7)
1.5 m (5ft)	kg					*7030	5250	*5160	3390	3280	2060	8.20
	lb					*15500	11570	*11380	7470	7230	4540	(26.9)
Ground Line	kg			*7120	*7120	*7680	5030	5250	3270	3420	2150	7.94
	lb			*15700	*15700	*16930	11090	11570	7210	7540	4740	(26.0)
-1.5 m (-5ft)	kg	*7040	*7040	*11150	9670	*7590	4970	5200	3230	3900	2450	7.31
	lb	*15520	*15520	*24580	21320	*16730	10960	11460	7120	8600	5400	(24.0)
-3.0 m (-10ft)	kg	*11230	*11230	*9630	*9630	*6670	5030			*3750	3240	6.19
	lb	*24760	*24760	*21230	*21230	*14700	11090			*8270	7140	(20.3)
-4.5 m (-15ft)	kg			*6270	*6270							
	lb			*13820	*13820							

Boom : 5.10 m (16'9") / Arm : 2.60 m (8'6") / Bucket : 0.76 m<sup>3</sup> (0.92 yd<sup>3</sup>) SAE heaped / Shoe : 600 mm (24") triple grouser

Load point height m (ft)		Load radius								At max. reach				
		1.5 m (5ft)		3.0 m (10ft)		4.5 m (15ft)		6.0 m (20ft)		7.5 m (25ft)		Capacity		Reach m (ft)
														
7.5 m (25ft)	kg											*3380	*3380	6.11
	lb											*7450	*7450	(20.0)
6.0 m (20ft)	kg							*3020	*3020			*3360	2660	7.37
	lb							*6660	*6660			*7410	5860	(24.2)
4.5 m (15ft)	kg							*3770	3720			*3410	2190	8.11
	lb							*8310	8200			*7520	4830	(26.6)
3.0 m (10ft)	kg			*7910	*7910	*5310	*5310	*4300	3560	*2810	2420	3130	1970	8.48
	lb			*17440	*17440	*11710	*11710	*9480	7850	*6190	5340	6900	4340	(27.8)
1.5 m (5ft)	kg			*8120	*8120	*6650	5270	*4920	3380	*3650	2350	3050	1900	8.53
	lb			*17900	*17900	*14660	11620	*10850	7450	*8050	5180	6720	4190	(28.0)
Ground Line	kg			*7910	*7910	*7500	5010	5220	3240	*3470	2280	3170	1970	8.28
	lb			*17440	*17440	*16530	11050	11510	7140	*7650	5030	6990	4340	(27.2)
-1.5 m (-5ft)	kg	*6710	*6710	*10690	9550	*7620	4900	5140	3170			3560	2220	7.69
	lb	*14790	*14790	*23570	21050	*16800	10800	11330	6990			7850	4890	(25.2)
-3.0 m (-10ft)	kg	*9990	*9990	*10280	9680	*6960	4930	*4870	3200			*3750	2830	6.64
	lb	*22020	*22020	*22660	21340	*15340	10870	*10740	7050			*8270	6240	(21.8)
-4.5 m (-15ft)	kg			*7470	*7470	*4960	*4960							
	lb			*16470	*16470	*10930	*10930							

Boom : 5.10 m (16'9") / Arm : 3.10 m (11'1") / Bucket : 0.76 m<sup>3</sup> (0.92 yd<sup>3</sup>) SAE heaped / Shoe : 600 mm (24") triple grouser

Load point height m (ft)		Load radius								At max. reach				
		1.5 m (5ft)		3.0 m (10ft)		4.5 m (15ft)		6.0 m (20ft)		7.5 m (25ft)		Capacity		Reach m (ft)
														
7.5 m (25ft)	kg											*3000	*3000	6.73
	lb											*6610	*6610	(22.1)
6.0 m (20ft)	kg							*2870	*2870			*3020	2360	7.88
	lb							*6330	*6330			*6660	5200	(25.9)
4.5 m (15ft)	kg							*3350	*3350	*2130	*2130	*3100	1970	8.57
	lb							*7390	*7390	*4700	*4700	*6830	4340	(28.1)
3.0 m (10ft)	kg					*4710	*4710	*3930	3580	*3090	2420	2870	1780	8.91
	lb					*10380	*10380	*8660	7890	*6810	5340	6330	3920	(29.2)
1.5 m (5ft)	kg			*10220	*10220	*6160	5330	*4620	3380	3730	2330	2790	1710	8.96
	lb			*22530	*22530	*13580	11750	*10190	7450	8220	5140	6150	3770	(29.4)
Ground Line	kg			*8670	*8670	*7210	5010	*5180	3220	3640	2250	2880	1760	8.73
	lb			*19110	*19110	*15900	11050	*11420	7100	8020	4960	6350	3880	(28.6)
-1.5 m (-5ft)	kg	*6310	*6310	*10330	9460	*7580	4850	5090	3120	*3230	2210	3190	1960	8.17
	lb	*13910	*13910	*22770	20860	*16710	10690	11220	6880	*7120	4870	7030	4320	(26.8)
-3.0 m (-10ft)	kg	*8950	*8950	*10900	9520	*7200	4830	5080	3110			*3630	2430	7.21
	lb	*19730	*19730	*24030	20990	*15870	10650	11200	6860			*8000	5360	(23.7)
-4.5 m (-15ft)	kg	*12430	*12430	*8640	*8640	*5790	4950					*3370	*3370	5.59
	lb	*27400	*27400	*19050	*19050	*12760	10910					*7430	*7430	(18.3)













- Lifting capacity is based on SAE J1097, ISO 10567.
- Lifting capacity of the Robex Series does not exceed 75% of the tipping load with the machine on firm, level ground or 87% of full hydraulic capacity.
- The load point is a hook located on the back of the bucket.
- (\*) indicates the load limited by hydraulic capacity.

# Lifting Capacities













## R180LC-9A 2-PIECE BOOM

 Rating over-front  Rating over-side or 360 degrees

Boom : 5.10 m (16' 9") / Arm : 2.20 m (7' 3") / Bucket : 0.76 m<sup>3</sup> (0.92 yd<sup>3</sup>) SAE heaped / Shoe : 600 mm (24") triple grouser

Load point height m (ft)		Load radius										At max. reach			
		1.5 m (5ft)		3.0 m (10ft)		4.5 m (15ft)		6.0 m (20ft)		7.5 m (25ft)		Capacity		Reach	
														m (ft)	
6.0 m (20ft)	kg												*3720	2840	7.06
	lb												*8200	6260	(23.2)
4.5 m (15ft)	kg							*4150	3700				3660	2310	7.83
	lb							*9150	8160				8070	5090	(25.7)
3.0 m (10ft)	kg					*5840	5630	*4600	3550				3330	2080	8.21
	lb					*12870	12410	*10140	7830				7340	4590	(26.9)
1.5 m (5ft)	kg					*6990	5230	*5120	3380	*3430	2350		3250	2010	8.27
	lb					*15410	11530	*11290	7450	*7560	5180		7170	4430	(27.1)
Ground Line	kg			*6220	*6220	*7560	4990	5270	3250				3400	2100	8.01
	lb			*13710	*13710	*16670	11000	11620	7170				7500	4630	(26.3)
-1.5 m (-5ft)	kg	*6220	*6220	*10360	9630	*7410	4930	5220	3200				*3680	2410	7.39
	lb	*13710	*13710	*22840	21230	*16340	10870	11510	7050				*8110	5310	(24.2)
-3.0 m (-10ft)	kg			*9130	*9130	*6390	5010						*3280	3180	6.28
	lb			*20130	*20130	*14090	11050						*7230	7010	(20.6)

Boom : 5.10 m (16' 9") / Arm : 2.60 m (8' 6") / Bucket : 0.76 m<sup>3</sup> (0.92 yd<sup>3</sup>) SAE heaped / Shoe : 600 mm (24") triple grouser

Load point height m (ft)		Load radius										At max. reach			
		1.5 m (5ft)		3.0 m (10ft)		4.5 m (15ft)		6.0 m (20ft)		7.5 m (25ft)		Capacity		Reach	
														m (ft)	
6.0 m (20ft)	kg												*3420	2580	7.48
	lb												*7540	5690	(24.5)
4.5 m (15ft)	kg												3380	2120	8.20
	lb												7450	4670	(26.9)
3.0 m (10ft)	kg							*4320	3560	*3220	2410		3090	1910	8.57
	lb							*9520	7850	*7100	5310		6810	4210	(28.1)
1.5 m (5ft)	kg			*7010	*7010	*6640	5260	*4900	3370	3760	2330		3010	1850	8.62
	lb			*15450	*15450	*14640	11600	*10800	7430	8290	5140		6640	4080	(28.3)
Ground Line	kg			*7070	*7070	*7400	4970	5240	3220	3690	2260		3130	1920	8.37
	lb			*15590	*15590	*16310	10960	11550	7100	8140	4980		6900	4230	(27.5)
-1.5 m (-5ft)	kg	*6050	*6050	*9980	9500	*7450	4870	5160	3150				3520	2170	7.78
	lb	*13340	*13340	*22000	20940	*16420	10740	11380	6940				7760	4780	(25.5)
-3.0 m (-10ft)	kg	*9510	*9510	*9830	9650	*6710	4900	*4670	3180				*3320	2770	6.76
	lb	*20970	*20970	*21670	21270	*14790	10800	*10300	7010				*7320	6110	(22.2)
-4.5 m (-15ft)	kg			*6820	*6820	*4540	*4540								
	lb			*15040	*15040	*10010	*10010								











- Lifting capacity is based on SAE J1097, ISO 10567.
- Lifting capacity of the Robex Series does not exceed 75% of the tipping load with the machine on firm, level ground or 87% of full hydraulic capacity.
- The load point is a hook located on the back of the bucket.
- (\*) indicates the load limited by hydraulic capacity.

# Lifting Capacities













## R180LCD-9A

 Rating over-front  Rating over-side or 360 degrees













Boom : 5.10 m (16' 9") / Arm : 2.20 m (7' 3") / Bucket : 0.76 m<sup>3</sup> (0.92 yd<sup>3</sup>) SAE heaped / Shoe : 600 mm (24") triple grouser

Load point height m (ft)		Load radius								At max. reach		
		1.5 m (5ft)		3.0 m (10ft)		4.5 m (15ft)		6.0 m (20ft)		Capacity		Reach m (ft)
												
7.5 m (25ft)	kg									*3750	*3750	5.60
	lb									*8270	*8270	(18.4)
6.0 m (20ft)	kg									*3660	3070	6.98
	lb									*8070	6770	(22.9)
4.5 m (15ft)	kg					*4570	*4570	*4110	3880	*3690	2510	7.76
	lb					*10080	*10080	*9060	8550	*8140	5530	(25.5)
3.0 m (10ft)	kg			*9100	*9100	*5790	*5790	*4600	3740	*3760	2260	8.15
	lb			*20060	*20060	*12760	*12760	*10140	8250	*8290	4980	(26.7)
1.5 m (5ft)	kg					*7030	5530	*5160	3580	*3740	2190	8.20
	lb					*15500	12190	*11380	7890	8250	4830	(26.9)
Ground Line	kg			*7120	*7120	*7680	5310	*5520	3460	3910	2280	7.94
	lb			*15700	*15700	*16930	11710	*12170	7630	8620	5030	(26.0)
-1.5 m (-5ft)	kg	*7040	*7040	*11150	10180	*7590	5240	*5450	3420	*3960	2600	7.31
	lb	*15520	*15520	*24580	22440	*16730	11550	*12020	7540	*8730	5730	(24.0)
-3.0 m (-10ft)	kg	*11230	*11230	*9630	*9630	*6670	5300			*3750	3420	6.19
	lb	*24760	*24760	*21230	*21230	*14700	11680			*8270	7540	(20.3)
-4.5 m (-15ft)	kg			*6270	*6270							
	lb			*13820	*13820							

Boom : 5.10 m (16' 9") / Arm : 2.60 m (8' 6") / Bucket : 0.76 m<sup>3</sup> (0.92 yd<sup>3</sup>) SAE heaped / Shoe : 600 mm (24") triple grouser

Load point height m (ft)		Load radius								At max. reach				
		1.5 m (5ft)		3.0 m (10ft)		4.5 m (15ft)		6.0 m (20ft)		7.5 m (25ft)		Capacity		Reach m (ft)
														
7.5 m (25ft)	kg										*3380	*3380	6.11	
	lb										*7450	*7450	(20.0)	
6.0 m (20ft)	kg						*3020	*3020			*3360	2800	7.37	
	lb						*6660	*6660			*7410	6170	(24.2)	
4.5 m (15ft)	kg						*3770	*3770			*3410	2320	8.11	
	lb						*8310	*8310			*7520	5110	(26.6)	
3.0 m (10ft)	kg			*7910	*7910	*5310	*5310	*4300	3750	*2810	2570	*3500	2090	8.48
	lb			*17440	*17440	*11710	*11710	*9480	8270	*6190	5670	*7720	4610	(27.8)
1.5 m (5ft)	kg			*8120	*8120	*6650	5550	*4920	3570	*3650	2490	3490	2020	8.53
	lb			*17900	*17900	*14660	12240	*10850	7870	*8050	5490	7690	4450	(28.0)
Ground Line	kg			*7910	*7910	*7500	5280	*5380	3430	*3470	2430	3630	2100	8.28
	lb			*17440	*17440	*16530	11640	*11860	7560	*7650	5360	8000	4630	(27.2)
-1.5 m (-5ft)	kg	*6710	*6710	*10690	11060	*7620	5180	*5460	3360			*3810	2360	7.69
	lb	*14790	*14790	*23570	22180	*16800	11420	*12040	7410			*8400	5200	(25.2)
-3.0 m (-10ft)	kg	*9990	*9990	*10280	10180	*6960	5200	*4870	3390			*3750	3000	6.64
	lb	*22020	*22020	*22660	22440	*15340	11460	*10740	7470			*8270	6610	(21.8)
-4.5 m (-15ft)	kg			*7470	*7470	*4960	*4960							
	lb			*16470	*16470	*10930	*10930							

Boom : 5.10 m (16' 9") / Arm : 3.10 m (11' 1") / Bucket : 0.76 m<sup>3</sup> (0.92 yd<sup>3</sup>) SAE heaped / Shoe : 600 mm (24") triple grouser

Load point height m (ft)		Load radius								At max. reach				
		1.5 m (5ft)		3.0 m (10ft)		4.5 m (15ft)		6.0 m (20ft)		7.5 m (25ft)		Capacity		Reach m (ft)
														
7.5 m (25ft)	kg											*3000	*3000	6.73
	lb											*6610	*6610	(22.1)
6.0 m (20ft)	kg						*2870	*2870				*3020	2490	7.88
	lb						*6330	*6330				*6660	5490	(25.9)
4.5 m (15ft)	kg						*3350	*3350	*2130	*2130		*3100	2090	8.57
	lb						*7390	*7390	*4700	*4700		*6830	4610	(28.1)
3.0 m (10ft)	kg					*4710	*4710	*3930	3770	*3090	2570	*3200	1890	8.91
	lb					*10380	*10380	*8660	8310	*6810	5670	*7050	4170	(29.2)
1.5 m (5ft)	kg			*10220	*10220	*6160	5600	*4620	3570	*3850	2470	3200	1830	8.96
	lb			*22530	*22530	*13580	12350	*10190	7870	*8490	5450	7050	4030	(29.4)
Ground Line	kg			*8670	*8670	*7210	5280	*5180	3410	*4100	2390	3310	1880	8.73
	lb			*19110	*19110	*15900	11640	*11420	7520	*9040	5270	7300	4140	(28.6)
-1.5 m (-5ft)	kg	*6310	*6310	*10330	9960	*7580	5120	*5420	3310	*3230	2350	*3570	2090	8.17
	lb	*13910	*13910	*22770	21960	*16710	11290	*11950	7300	*7120	5180	*7870	4610	(26.8)
-3.0 m (-10ft)	kg	*8950	*8950	*10900	10020	*7200	5110	*5110	3300			*3630	2580	7.21
	lb	*19730	*19730	*24030	22090	*15870	11270	*11270	7280			*8000	5690	(23.7)
-4.5 m (-15ft)	kg	*12430	*12430	*8640	*8640	*5790	5230					*3370	*3370	5.59
	lb	*27400	*27400	*19050	*19050	*12760	11530					*7430	*7430	(18.3)

- Lifting capacity is based on SAE J1097, ISO 10567.
- Lifting capacity of the Robex Series does not exceed 75% of the tipping load with the machine on firm, level ground or 87% of full hydraulic capacity.
- The load point is a hook located on the back of the bucket.
- (\*) indicates the load limited by hydraulic capacity.













# Lifting Capacities













## R180NLC-9A

 Rating over-front  Rating over-side or 360 degrees













Boom : 5.10 m (16'9") / Arm : 2.20 m (7'3") / Bucket : 0.76 m<sup>3</sup> (0.92 yd<sup>3</sup>) SAE heaped / Shoe : 600 mm (24") triple grouser

Load point height m (ft)		Load radius								At max. reach		
		1.5 m (5ft)		3.0 m (10ft)		4.5 m (15ft)		6.0 m (20ft)		Capacity		Reach m (ft)
												
7.5 m (25ft)	kg									*3750	*3750	5.60
	lb									*8270	*8270	(18.4)
6.0 m (20ft)	kg									*3660	2550	6.98
	lb									*8070	5620	(22.9)
4.5 m (15ft)	kg					*4570	*4570	*4110	3230	3680	2060	7.76
	lb					*10080	*10080	*9060	7120	8110	4540	(25.5)
3.0 m (10ft)	kg			*9100	*9100	*5790	4880	*4600	3100	3340	1830	8.15
	lb			*20060	*20060	*12760	10760	*10140	6830	7360	4030	(26.7)
1.5 m (5ft)	kg					*7030	4530	*5160	2940	3260	1770	8.20
	lb					*15500	9990	*11380	6480	7190	3900	(26.9)
Ground Line	kg			*7120	*7120	*7680	4320	5220	2820	3400	1840	7.94
	lb			*15700	*15700	*16930	9520	11510	6220	7500	4060	(26.0)
-1.5 m (-5ft)	kg	*7040	*7040	*11150	9670	*7590	4250	5160	2780	3870	2110	7.31
	lb	*15520	*15520	*24580	21320	*16730	9370	11380	6130	8530	4650	(24.0)
-3.0 m (-10ft)	kg	*11230	*11230	*9630	*9630	*6670	4310			*3750	2800	6.19
	lb	*24760	*24760	*21230	*21230	*14700	9500			*8270	6170	(20.3)
-4.5 m (-15ft)	kg			*6270	*6270							
	lb			*13820	*13820							

Boom : 5.10 m (16'9") / Arm : 2.60 m (8'6") / Bucket : 0.76 m<sup>3</sup> (0.92 yd<sup>3</sup>) SAE heaped / Shoe : 600 mm (24") triple grouser

Load point height m (ft)		Load radius								At max. reach				
		1.5 m (5ft)		3.0 m (10ft)		4.5 m (15ft)		6.0 m (20ft)		7.5 m (25ft)		Capacity		Reach m (ft)
														
7.5 m (25ft)	kg											*3380	3290	6.11
	lb											*7450	7250	(20.0)
6.0 m (20ft)	kg							*3020	*3020			*3360	2320	7.37
	lb							*6660	*6660			*7410	5110	(24.2)
4.5 m (15ft)	kg							*3770	3250			*3410	1890	8.11
	lb							*8310	7170			*7520	4170	(26.6)
3.0 m (10ft)	kg			*7910	*7910	*5310	4930	*4300	3100	*2810	2090	3110	1690	8.48
	lb			*17440	*17440	*11710	10870	*9480	6830	*6190	4610	6860	3730	(27.8)
1.5 m (5ft)	kg			*8120	*8120	*6650	4550	*4920	2930	*3650	2020	3030	1620	8.53
	lb			*17900	*17900	*14660	10030	*10850	6460	*8050	4450	6680	3570	(28.0)
Ground Line	kg			*7910	*7910	*7500	4290	5180	2790	*3470	1960	3150	1680	8.28
	lb			*17440	*17440	*16530	9460	11420	6150	*7650	4320	6940	3700	(27.2)
-1.5 m (-5ft)	kg	*6710	*6710	*10690	7980	*7620	4190	5110	2720			3540	1900	7.69
	lb	*14790	*14790	*23570	17590	*16800	9240	11270	6000			7800	4190	(25.2)
-3.0 m (-10ft)	kg	*9990	*9990	*10280	8100	*6960	4210	*4870	2750			*3750	2440	6.64
	lb	*22020	*22020	*22660	17860	*15340	9280	*10740	6060			*8270	5380	(21.8)
-4.5 m (-15ft)	kg			*7470	*7470	*4960	4390							
	lb			*16470	*16470	*10930	9680							

Boom : 5.10 m (16'9") / Arm : 3.10 m (11'1") / Bucket : 0.76 m<sup>3</sup> (0.92 yd<sup>3</sup>) SAE heaped / Shoe : 600 mm (24") triple grouser

Load point height m (ft)		Load radius								At max. reach				
		1.5 m (5ft)		3.0 m (10ft)		4.5 m (15ft)		6.0 m (20ft)		7.5 m (25ft)		Capacity		Reach m (ft)
														
7.5 m (25ft)	kg											*3000	2790	6.73
	lb											*6610	6150	(22.1)
6.0 m (20ft)	kg							*2870	*2870			*3020	2050	7.88
	lb							*6330	*6330			*6660	4520	(25.9)
4.5 m (15ft)	kg							*3350	3280	*2130	*2130	*3100	1690	8.57
	lb							*7390	7230	*4700	*4700	*6830	3730	(28.1)
3.0 m (10ft)	kg					*4710	*4710	*3930	3120	*3090	2090	2850	1520	8.91
	lb					*10380	*10380	*8660	6880	*6810	4610	6280	3350	(29.2)
1.5 m (5ft)	kg			*10220	8620	*6160	4600	*4620	2930	3700	2000	2770	1450	8.96
	lb			*22530	19000	*13580	10140	*10190	6460	8160	4410	6110	3200	(29.4)
Ground Line	kg			*8670	8030	*7210	4290	5160	2760	3610	1920	2860	1500	8.73
	lb			*19110	17700	*15900	9460	11380	6080	7960	4230	6310	3310	(28.6)
-1.5 m (-5ft)	kg	*6310	*6310	*10330	7890	*7580	4140	5060	2670	*3230	1880	3170	1670	8.17
	lb	*13910	*13910	*22770	17390	*16710	9130	11160	5890	*7120	4140	6990	3680	(26.8)
-3.0 m (-10ft)	kg	*8950	*8950	*10900	7950	*7200	4120	5040	2660			*3630	2080	7.21
	lb	*19730	*19730	*24030	17530	*15870	9080	11110	5860			*8000	4590	(23.7)
-4.5 m (-15ft)	kg	*12430	*12430	*8640	8170	*5790	4240					*3370	3230	5.59
	lb	*27400	*27400	*19050	18010	*12760	9350					*7430	7120	(18.3)

- Lifting capacity is based on SAE J1097, ISO 10567.
- Lifting capacity of the Robex Series does not exceed 75% of the tipping load with the machine on firm, level ground or 87% of full hydraulic capacity.
- The load point is a hook located on the back of the bucket.
- (\*) indicates the load limited by hydraulic capacity.

## STANDARD EQUIPMENT R180LC-9A

### ISO Standard cabin

All-weather steel cab with 360° visibility
Safety glass windows
Rise-up type windshield wiper
Sliding fold-in front window
Sliding side window (LH)
One key fits all lockable doors
Hot & cool box
Storage compartment & Ashtray
Radio / MP3 Player with remote control and USB-input
Handsfree mobile phone system with USB-charging device
Transparent cabin roof-cover
12 volt power outlet (24V DC to 12V DC converter)
Sun visor
Rain guard - front window
Computer aided power optimization (CAPO) system
3-power modes, 2-work modes, User mode
Auto & one-touch deceleration system
Auto warm-up system
Overheat prevention system
Automatic temperature control
Air conditioner & heater
Defroster
Self-diagnostics system
Starting Aid (air grid heater) for cold weather
Centralized monitoring
LCD display
Engine speed or Trip meter
Clock
Gauges
- Fuel level gauge
- Engine coolant temperature gauge
- Hyd. oil temperature gauge
Warning lamps
- Engine warning
- Overload
- Communication error
- Low battery
- Air filter clogging
Indicators
- Max power
- Low speed/High speed
- Fuel warmer
- Auto deceleration
Rearview camera
Door and cab locks, one key
Three outside rearview mirrors
Mechanical suspension seat with heater
Adjustable joysticks
Console box tilting system
Four front working lights
Electric horn
Batteries (2 x 12V x 100 AH)
Battery master switch
Removable clean-out screen for coolers
Automatic swing brake
Fuel pre-filter with fuel warmer
Boom holding system
Arm holding system
Track shoes (600 mm; 24")
Track rail guard
Accumulator for lowering work equipment
Lower frame under cover
Viscous fan clutch
Fuel filler pump (35 ℓ/min)
Safety lock valve for boom cylinder with overload warning device

Double-acting piping kit (clamshell, etc.)
Travel alarm
Boom
5.1 m; 16' 9"
Arm
2.6 m; 8' 6"
Cabin ROPS (ISO 12117-2)
ROPS (Roll Over Protective Structure)
Hi-mate (Remote Management System)

## OPTIONAL EQUIPMENT R180LC-9A

Beacon lamp
Safety lock valve for arm cylinder
Single-acting piping kit (breaker, etc.)
Quick coupler
Boom
5.1 m; 16' 9" - hydraulic adjustable
Arm
2.2 m; 7' 3"
3.1 m; 10' 2" - not for hydraulic adjustable boom
Cabin FOPS/FOG (ISO/DIS 10262 Level II)
FOPS (Falling Object Protective Structure)
FOG (Falling Object Guard)
Cabin roof-steel cover
Cabin lights
Track shoes
Triple grousers shoe (500 mm; 20")
Triple grousers shoe (700 mm; 28") - not for R180NLC-9A
Triple grousers shoe (800 mm; 32") - not for R180NLC-9A
Dozer blade - R180LCD-9A
640 mm (2' 1") x 2,750 mm (9' 1")
640 mm (2' 1") x 2,850 mm (9' 5")
640 mm (2' 1") x 3,050 mm (10' 1")
Additional lower frame - reinforced under cover
Seat
Adjustable air suspension seat
Adjustable air suspension seat with heater
Mechanical suspension seat
Pattern change valve (2 patterns)

- \* Standard and optional equipment may vary. Contact your Hyundai dealer for more information. The machine may vary according to international standards.
- \* The photos may include attachments and optional equipment that are not available in your area.
- \* Materials and specifications are subject to change without advance notice.
- \* All imperial measurements rounded off to the nearest pound or inch.

PLEASE CONTACT

