

DIECI

A M E R I C A S
TELEHANDLERS



55.19

A 55.19

PERFORMANCE

Vehicle model	A 55.19-C	A 55.19-O
Maximum capacity	5500 lb (2495 kg)	5500 lb (2495 kg)
Maximum lifting height	19 ft (5,78 m)	19 ft (5,78 m)
Maximum horizontal extension	10,9 ft (3,3 m)	10,9 ft (3,3 m)
Fork swiveling angle	129°	129°
Pull-out force	17085 lbf (7600 daN)	17085 lbf (7600 daN)
Towing force	9892 lbf (4400 daN)	9892 lbf (4400 daN)
Maximum climb angle	40%	40%
Maximum mass	12522 lb (5680 kg)	12522 lb (5680 kg)
Max speed (referred to wheels with maximum permitted diameter)	18,6 mph (30 km/h)	18,6 mph (30 km/h)

BOOM

Vehicle model	A 55.19-C	A 55.19-O
Lifting	7,8 s	7,8 s
Descent	4,1 s	4,1 s
Extension	6,1 s	6,1 s
Retraction	3,4 s	3,4 s
Forward swiveling	3,5 s	3,5 s
Reverse swiveling	2,2 s	2,2 s

ENGINE

Vehicle model	A 55.19-C	A 55.19-O
Brand	Kubota	Kubota
Nominal power	73 HP (54,6 kW)	73 HP (54,6 kW)
@rpm	2600 rpm	2600 rpm
Operation	4-stroke	4-stroke
Injection	Electronic, Common rail	Electronic, Common rail
Number and arrangement of cylinders	4, Vertical in line	4, Vertical in line
Displacement	203 in ³ (3331 cm ³)	203 in ³ (3331 cm ³)
Consumption	380 lb/Hp h (231 g/kWh)	380 lb/Hp h (231 g/kWh)
@rpm	2600 rpm	2600 rpm
Emission standard	Stage IIIB/Tier 4i	Stage IIIB/Tier 4i
Exhaust gas treatment	Particulate filter (DPF)	Particulate filter (DPF)
Cooling system	Liquid	Liquid
Intake	Turbo compressor	Turbo compressor

DIFFERENTIAL AXLES

Vehicle model	A 55.19-C	A 55.19-O
Type of axles	2 steering, with 4 planetary reduction gears	2 steering, with 4 planetary reduction gears
Type of steering	4 wheels / transversal / 2 wheels	4 wheels / transversal / 2 wheels
Front axle	Rigid	Rigid
Rear axle	Swinging	Swinging
Service braking	Oil bath on front axle	Oil bath on front axle
Parking braking	Negative actuation with electrical control	Negative actuation with electrical control

HYDRAULIC SYSTEM

Vehicle model	A 55.19-C	A 55.19-O
Hydraulic pump type	Gear pump for power steering and movements	Gear pump for power steering and movements
Hydraulic pump capacity	21,1 gal/min (80 L/min)	21,1 gal/min (80 L/min)
Max. operating pressure	3336 psi (23,0 MPa)	3336 psi (23,0 MPa)
Distributor control	4in1 proportional Joystick	4in1 proportional Joystick

REFUELING

Vehicle model	A 55.19-C	A 55.19-O
Hydraulic system (total)	18,49 gal (70,0 L)	18,49 gal (70,0 L)
Fuel tank	21,13 gal (80,0 L)	21,13 gal (80,0 L)

TIRES

Vehicle model	A 55.19-C	A 55.19-O
Standard tires	12x16.5"	12x16.5"
Optional tires	12x18"	12x18"

COMPLIANCE WITH STANDARDS

Vehicle model	A 55.19-C	A 55.19-O
Marking	ANSI/ITSDF B56.6 - CSA B335 - UL558	ANSI/ITSDF B56.6 - CSA B335 - UL558

STANDARD FORKS

Width section	120 mm (4,7 in)
Height section	45 mm (1,8 in)

DIMENSIONS

Vehicle model	A 55.19-C	A 55.19-O
A	10,6 in (270 mm)	10,6 in (270 mm)
B	38,8 in (985 mm)	38,8 in (985 mm)
C	92,5 in (2350 mm)	92,5 in (2350 mm)
D	30,1 in (765 mm)	30,1 in (765 mm)
F	139,2 in (3535 mm)	139,2 in (3535 mm)
G	162,4 in (4125 mm)	162,4 in (4125 mm)
H	76,8 in (1950 mm)	76,8 in (1950 mm)
I	72,8 in (1850 mm)	72,8 in (1850 mm)
L	59,1 in (1500 mm)	59,1 in (1500 mm)
M	72,8 in (1850 mm)	72,8 in (1850 mm)
P	57,5 in (1460 mm)	57,5 in (1460 mm)
Q	140 in (3555 mm)	140 in (3555 mm)
S	56,4 in (1433 mm)	56,4 in (1433 mm)
T	7,9 in (200 mm)	7,9 in (200 mm)

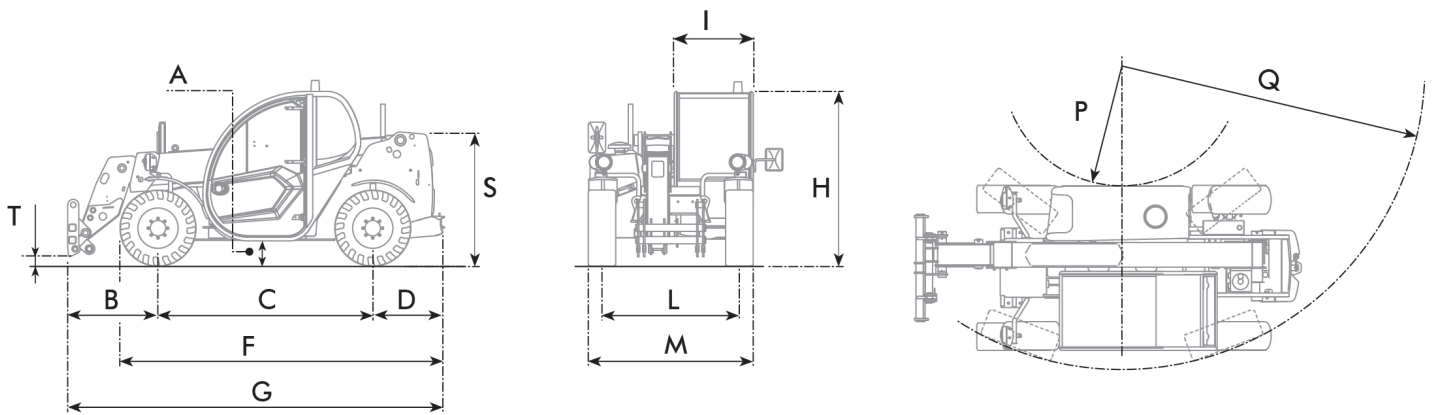

**MAX
5500 lb**

24 in

DOCID10000969

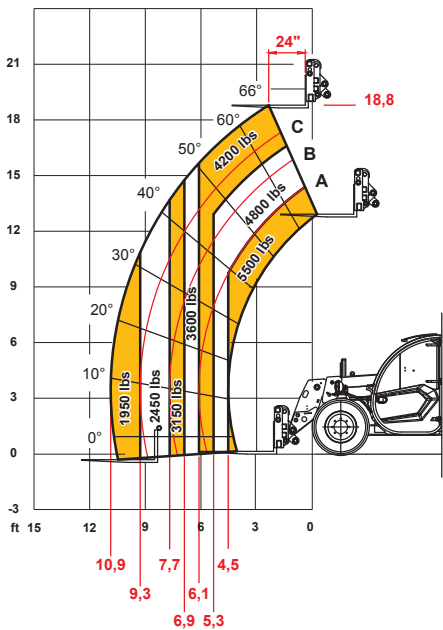

ANSI B56.6

A 55.19



Headquarters: 5500 Nafex Way Suite 3, Fort Worth, TX 76131

P: 214-227-2448 - F: 412.458.1084 - website: www.dieci-americas.com

SKT A 55.19 - Dieci Americas -UK | v. 1.8